

Megaplex-2100/2104

ML-1/2E1T1, MLF-1/2E1T1

Copper or Fiber Optic Interface, Single/Dual E1/T1 Main Link Modules



- One or two E1 or T1 link interfaces with built-in non-blocking DS0 cross-connect between any ML modules
- Built-in LTU (E1) or CSU (T1) on copper interface ML modules
- Various fiber optic interface options, with ranges of up to 100 km (62 miles), for MLF modules
- Main link module redundancy, including ring redundancy

The ML-1/2 electrical copper interface and MLF-1/2 fiber optic interface modules connect Megaplex-2100/2104 to one or two E1/T1 lines.

Multiple main link modules can be installed in a single chassis, giving Megaplex a capacity of up to four full E1 links or five full T1 links, for both point to point and point-to-multipoint applications. Alternatively, multiple fractional E1/T1 links can be used.

The E1/T1 ring functionality can be configured in a single database, allowing an unlimited number of nodes per ring with protection speed of up to 5 seconds

E1 link modules are compatible with all carrier-provided E1 services, meeting the requirements of ITU-T Recommendations G.703, G.704 and G.732. They support both two (256N) and 16 (256S) frames per multiframe formats. They also support CRC-4 and E bit, in compliance with G.704 recommendations. Zero suppression over the lines is HDB3.

T1 link modules are compatible with all carrier provided T1 services, meeting ANSI and AT&T requirements. They support both D4 and ESF framing formats. Zero suppression methods – transparent coding, B7Z5, or B8Z5 – can be selected separately for each link interface.

The ML-1T1 and ML-2T1 copper interface modules have an integral user-enabled CSU, for transmission ranges of up to 1.6 km (1 mile). The ML-1E1 and ML-2E1 copper interface modules are equipped with an integral user-enabled LTU, ensuring ranges of up to 2 km (1.2 miles).

The MLF fiber optic interface modules connect Megaplex-2100 to fiber optic lines, eliminating the need for an external fiber optic modem or repeater. Links of these modules operate at either E1 (2.048 Mbps) or T1 (1.544 Mbps) rate, providing secure links in hazardous or hostile environments.

With MLF modules, the E1 or T1 electrical signal is converted into a transmitted optical signal using a LED or laser. At the other end of the fiber line, the optical signal is converted back into an electrical signal and amplified to the required level by the remote MLF module.

Several optical interfaces are available for MLF modules (see *Table 1*).

Connecting Megaplex-2100/2104 to various E1 and T1 services



ML-1/2E1T1, MLF-1/2E1T1

Copper or Fiber Optic Interface, Single/Dual E1/T1 Main Link Modules

The MLF modules are compatible with RAD's standalone FOM-E1/T1 fiber modem and with the fiber modules of FCD, DXC and other Megaplex systems.

The internal cross-connect matrix of the ML and MLF main link modules routes voice and data channels from any I/O module installed in the chassis to any installed main link. The matrix can route voice and data traffic from any link to any other link. The non-blocking full cross-connect feature enables flexible timeslot assignment and efficient utilization of E1/T1 bandwidth. It also facilitates drop&insert, bypass and broadcast multi-link applications.

Note: A total of 124 timeslots can be allocated, either for transmission of I/O channels or for bypassing timeslots between links of different modules.

Additional main link modules can be installed in the Megaplex-2100 chassis to operate as hot standby modules. The backup module links and the active module links are connected to the same E1/T1 lines via Y-cables, providing full redundancy in case of main link hardware failure. Alternatively, multiple links can be configured for load sharing with optional priority bumping, ensuring continuous operation of the most important channels if one of the links fails.

Extensive transmission reliability can be provided by 1:1 protective switching between any two links in case of line

failure. 1:1 protective switching between the two links of a dual-link module occurs within 50 msec of a link failure.

A Megaplex chassis can be equipped with a combination of fiber and non-fiber main link modules.

In copper dual-link modules, an optional port bypass relay connects the E1/T1 main links when the module is not powered. This enables critical traffic (such as inband network management bits) to pass undisturbed through the links of a non-powered unit, to other units connected in a daisy chain topology.

Note: The bypass relay is not for use in the Y-cable protection mode.

E1 link modules support R2 signaling with transparent MFC/DECADIC for setting up, metering and disconnecting phone calls. This enables placement of a Megaplex between an older R2-PBX and a digital (E1-CAS) PBX. In addition to ITU-T standard R2 protocol, the E1 link modules comply with several predefined national PTT protocols, as well as user-definable variations.

System timing can be derived from an external station clock. This clock can then be passed to other connected Megaplex units. A dedicated RJ-45 connector is provided on the module panel for receiving the external station clock signal.

Note: The station clock connector is not provided on dual-link fiber MLF modules.

Diagnostic capabilities of dual-port modules feature local and remote loopbacks on each module port, local and remote loopbacks per timeslot (including split timeslots), and BER tests per port and per timeslot. Single-port modules have local and remote loopbacks on each module port. Performance statistics for each of the two main links can be obtained and analyzed via the Megaplex management system.

T1 link modules have code-activated network line and network payload loopbacks. When ESF is used, T1 main link statistics are stored in memory, in compliance with both ANSI and AT&T requirements.

Main link and system parameters are monitored and controlled via a terminal interface, or via the RADview Element Management System.

Specifications

NUMBER OF LINKS (PER MODULE)

ML-1E1, ML-1T1, MLF-1E1, MLF-1T1: 1
ML-2E1, ML-2T1, MLF-2E1, MLF-2T1: 2

E1 INTERFACE (ALL E1 MODULES)

Compliance

ITU-T G.703, G.704, G.732
(Including CRC-4 and E bit)

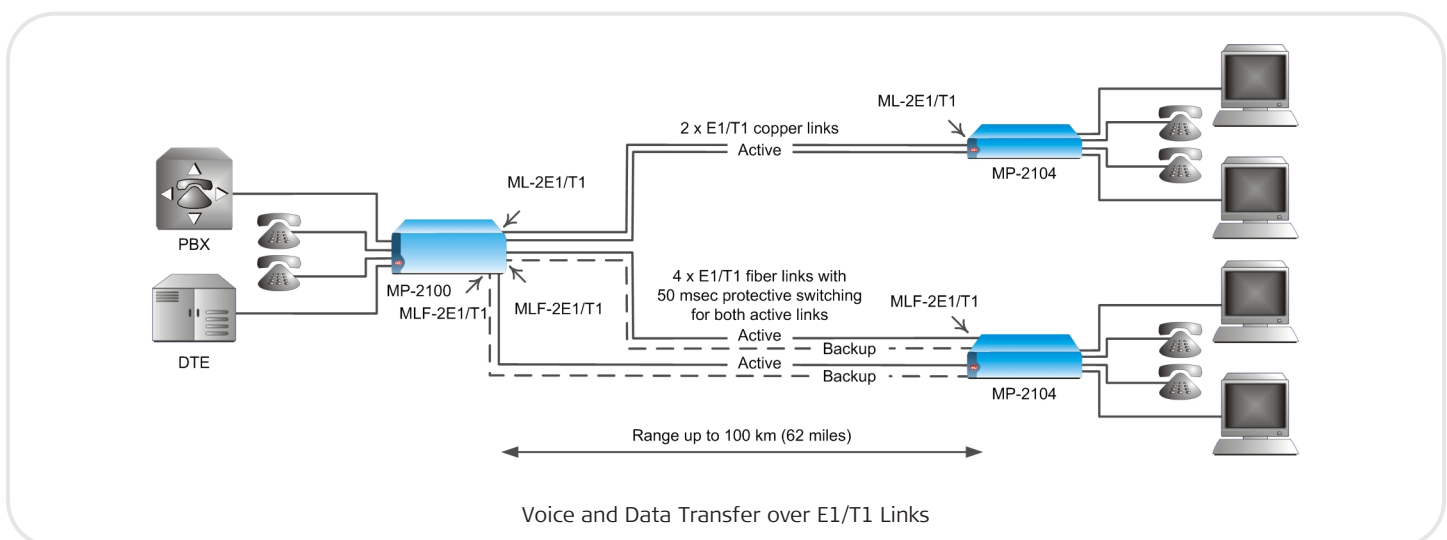

Framing

2 frames (256N) or 16 frames (256S) per multiframe

Data Rate (per link)

2.048 Mbps

Line Code

HDB3

Jitter Performance

As per ITU-T G.823

T1 INTERFACE (ALL T1 MODULES)

Compliance

AT&T TR-62411, PUB 54016; ANSI T1.107 and T1.403

Framing

D4, ESF

Data Rate (per link)

1.544 Mbps

Line Code

Bipolar AMI

Zero Suppression

Transparent, B7Z5, B8Z5

Jitter Performance

As per AT&T TR-62411

COPPER E1 INTERFACE (ML-1E1, ML-2E1)

Impedance

Balanced 4-wire: 120Ω
Unbalanced coax: 75Ω

Signal Level

Receive:

Without LTU: 0 to -12 dBm
With LTU: 0 to -36 dBm

Transmit:

Balanced: ±3V (±10%)
Unbalanced: ±2.37V (±10%)

Connectors (per link)

Balanced: RJ-45

Unbalanced: pair of mini BNC (1.0/2.3 mm SMC), female

Note: CBL-MINIBNC-BNC cable is available for converting from mini BNC connector to standard BNC coax interface (see Ordering)

COPPER T1 INTERFACE (ML-1T1, ML-2T1)

Impedance

Balanced 4-wire: 100Ω

Signal Level

Receive:

Without CSU: 0 to -10 dBm
With CSU: 0 to -34 dBm

Transmit:

Without CSU: ±3V (±10%),
user adjustable, measured at 0 to 655 ft
With CSU: 0, -7.5, -15, -22 dBm

Connectors (per link)

RJ-45

FIBER OPTIC INTERFACE (MLF-1E1, MLF-2E1, MLF-1T1, MLF-2T1)

Specifications and Range

See *Table 1*

Connectors (per link)

Pair of ST, FC/PC or SC (see *Ordering*)

TIMING

Transmit Timing

Internal clock

Loopback (recovered from the receive signal)

External clock from I/O module interface

Station clock (not for MLF-2)

Station Clock Interface

(not available on MLF-2)

Bit rate: 1.544 (T1)/2.048 MHz (E1)

Line code: AMI Connector: RJ-45

Format: Unframed 1s or RS-422

squarewave (jumper-selectable)

GENERAL

Diagnostics

Local and remote loopbacks on each module port

Local and remote loopbacks per timeslot

Dual-port modules only:

Local BER test toward local side on port and timeslot (including split timeslots)

Remote BER test toward remote side on port and timeslot (including split timeslots)

Local test tone injection toward local side

Remote test tone injection toward remote side

T1 modules only:

Network line loopback

Network payload loopback

CSU network loopback

Statistics (T1 modules only)

Full statistical diagnostics capability according to ANSI T1.403-1989

Local support of ESF diagnostics according to AT&T PUB 54016

Indicators

Per module: Alarm

Per link: On-line, Test, Local and Remote sync loss

Configuration

Programmable via terminal interface, or RADview network management system

Power Consumption

| Module | Current [A] | Power [W] |
|---------|-------------|-----------|
| ML-1E1 | 1.22 | 6.1 |
| ML-2E1 | 1.26 | 6.3 |
| ML-1T1 | 1.22 | 6.1 |
| ML-2T1 | 1.26 | 8.9 |
| MLF-1E1 | 1.60 | 8.0 |
| MLF-2E1 | 1.80 | 9.0 |
| MLF-1T1 | 1.60 | 8.0 |
| MLF-2T1 | 1.80 | 9.0 |

Environment

Operating temperature: -10°C to 55°C (14°F to 131°F)

Storage temperature: -20°C to +70°C (-4°F to +158°F)

Humidity: up to 95%, non-condensing

Table 1. Fiber Optic Interface Characteristics

| Wavelength [nm] | Fiber Type | Typical Maximum Range | |
|-----------------|-----------------------|-----------------------|---------|
| | | [km] | [miles] |
| 850 | 62.5/125 μm multimode | 5 | 3 |
| 1310 | 9/125 μm single-mode | 62 | 38 |
| 1550 | 9/125 μm single-mode | 100 | 62 |

ML-1/2E1T1, MLF-1/2E1T1

Copper or Fiber Optic Interface, Single/Dual E1/T1 Main Link Modules

Ordering

STANDARD CONFIGURATIONS

- MP-2100M-ML-1E1
- MP-2100M-ML-1T1
- MP-2100M-ML-2E1
- MP-2100M-ML-2T1
- MP-2100M-MLF-1E1/FC/13L
- MP-2100M-MLF-1E1/SC/13L
- MP-2100M-MLF-1E1/ST/13L
- MP-2100M-MLF-1T1/SC/13L
- MP-2100M-MLF-1T1/ST/13L
- MP-2100M-MLF-2E1/FC/13L
- MP-2100M-MLF-2E1/SC/13L
- MP-2100M-MLF-2E1/ST/13L
- MP-2100M-MLF-2T1/FC/13L
- MP-2100M-MLF-2T1/SC/13L
- MP-2100M-MLF-2T1/ST/13L

SPECIAL CONFIGURATIONS

- MP-2100M-ML-1@**
Single Copper Interface Main Link Module for MP-2100/2104
- MP-2100M-ML-2@/^**
Dual Copper Interface Main Link Module for MP-2100/2104
- MP-2100M-MLF-1@/#/+**
Single Fiber Optic Interface Main Link Module for MP-2100/2104
- MP-2100M-MLF-2@/#/+**
Dual Fiber Optic Interface Main Link Module for MP-2100/2104

Legend

- @ Link:
 - E1** E1 link(s)
 - T1** T1 link(s)
- ^ **BP** Port bypass between dual copper links (default is without port bypass)
- # Fiber optic connector:
 - ST** ST type connector
 - SC** SC type connector

- FC** FC type connector
- + Fiber optic interface wavelength:
 - 85** 850 nm, multimode, laser
 - 13L** 1310 nm, single mode, laser
 - 15L** 1550 nm, single mode, laser

OPTIONAL ACCESSORIES







CBL-MINIBNC-BNC/*
Cable for connecting the ML-1E1/ML-2E1 mini BNC unbalanced connectors to standard BNC coaxial connectors. (A separate cable must be ordered for each individual mini BNC connector.)

CBL-MINIBNC-MINIBNC/*
Cable for connecting a ML-1E1/ML-2E1 mini BNC unbalanced connector to another mini BNC interface. (A separate cable must be ordered for each individual mini BNC connector.)

Legend

- * Cable length:
 - 2.5METER** 2.5m/8.2 ft
 - 5METER** 5m/16.4 ft

Table 2. Megaplex Main Link Modules

| | ML-E1/T1 | MLF-E1/T1 | ML-8E1/8T1 | MSL-8 | ML-IP | ML-20N |
|---------------------------|---|---|---|--|---|---|
| Feature |  |  |  |  |  |  |
| Interface | E1/T1 | E1/T1 | E1/T1 | SHDSL | ETH (TDMoIP) | n x 64 kbps |
| Number of Channels | 1/2 | 1/2 | 8 | 8 | 2 | 1/2 |
| Redundancy | Link | Link | None | None | Bundle | Link |
| Ring | E1/T1 | E1/T1 | None | None | RFER | None |

International Headquarters
24 Raoul Wallenberg Street
Tel Aviv 69719, Israel
Tel. 972-3-6458181
Fax 972-3-6498250, 6474436
E-mail market@rad.com

North America Headquarters
900 Corporate Drive
Mahwah, NJ 07430, USA
Tel. 201-5291100
Toll free 1-800-4447234
Fax 201-5295777
E-mail market@rad.com

www.rad.com

Order this publication by Catalog No. 803265



data communications
The Access Company